

# **ST70 Autopilot Controller**

## Installation Guide

Document reference: 87071-1  
Date: 17th March 2007



---

## Contents

<b>Chapter 1:Before you begin</b> .....	1
1.1 Installation overview .....	1
1.2 Certified installation .....	1
1.3 Further assistance .....	1
1.4 Product documents .....	2
<b>Chapter 2:Planning</b> .....	3
2.1 System overviews .....	3
2.2 Positioning the ST70 autopilot controller .....	5
2.3 Parts supplied .....	7
2.4 Parts not supplied .....	8
<b>Chapter 3:Installation</b> .....	9
3.1 To install the autopilot controller .....	9
3.2 Commissioning .....	13
<b>Chapter 4:Technical specifications</b> .....	15
<b>Chapter 5:Templates</b> .....	17



# Preface

## Warnings and cautions

**WARNING: Product installation and operation**

**This equipment must be installed, commissioned and operated in accordance with the Raymarine instructions provided. Failure to do so could result in personal injury, damage to your boat and/or poor product performance. Before you install the ST70 autopilot controller, check that individual components are the correct voltage for your boat's supply.**

**WARNING: Electrical safety**

**Make sure you have switched off the power supply before you start installing this product.**

**WARNING: Navigational safety**

**Although we have designed this product to be accurate and reliable, many factors can affect its performance. Therefore, it should serve only as an aid to navigation and should never replace commonsense and navigational judgement. Always maintain a permanent watch so you can respond to situations as they develop.**

---

As correct performance of the boat's steering is critical for safety, we **STRONGLY RECOMMEND** that an Authorized Raymarine Service Representative fits this product. You will only receive full warranty benefits if you can show that an Authorized Raymarine Service Representative has installed or commissioned this product.

## Electromagnetic Compatibility (EMC) conformance

Raymarine equipment and accessories conform to the appropriate Electromagnetic Compatibility (EMC) regulations for use in the recreational marine environment. Correct installation is required to ensure that EMC performance is not compromised.

Always check the installation before going to sea to make sure that it is not affected by radio transmissions, engine starting or other forms of interference.

To do this:

1. Turn on all transmitting equipment (radar, VHF radio, etc.).
2. Check that all electronic systems are unaffected by interference from the transmitting equipment.

---

## EMC installation guidelines

Raymarine equipment and accessories conform to the appropriate Electromagnetic Compatibility (EMC) regulations. This minimizes electromagnetic interference between equipment, which could otherwise affect the performance of your system.

Correct installation is required to ensure that EMC performance is not compromised.

For **optimum** EMC performance, we make the following recommendations:

- Place Raymarine equipment and cables at least 3 ft (1 m) from any equipment that transmits, or cables that carry, radio signals from VHF radios, cables and antennas. In the case of SSB radios, the distance should be increased to 7 ft. (2 m).
- Place Raymarine equipment and cables more than 7 ft (2 m) from the path of a radar beam. A radar beam can normally be assumed to spread 20 degrees above and below the radiating element.
- Use a power source separate from that used for engine-start. This is important to prevent erratic behavior and data loss which can occur if the engine-start does not have a separate battery.
- Use Raymarine-specified cables.
- Do not cut or extend cables unless doing so is detailed in the installation manual.

### Remember

Where constraints on the installation prevent any of the above recommendations:

- Always allow the maximum separation possible between different items of electrical equipment.

This will provide the best conditions for good EMC performance of the installation.

### Suppression ferrites

Raymarine cables may be fitted with suppression ferrites. These are necessary for correct EMC performance. Any ferrite removed during installation must be replaced as soon as installation is complete.

Use only ferrites of the correct type, supplied by Raymarine authorized dealers.

### Connections to other equipment

If Raymarine equipment is to be connected to other equipment using a cable not supplied by Raymarine, a Raymarine suppression ferrite **MUST** always be attached to the cable near the Raymarine unit.

## EMC Servicing and maintenance

- Undue noise and interference may be a symptom of an EMC-related problem. Please report any EMC-related problem to your nearest Raymarine dealer. We use such information to improve our quality standards.
- To minimize any EMC related problems and ensure the best possible performance from your Raymarine equipment, follow the guidelines given in the installation instructions.

## Product disposal



### **Waste Electrical and Electronic (WEEE) Directive**

The WEEE Directive requires the recycling of waste electrical and electronic equipment.

Whilst the WEEE Directive does not apply to some of Raymarine's products, we support its policy and ask you to be aware of how to dispose of this product.

The crossed out wheellie bin symbol, illustrated above, and found on our products signifies that this product should not be disposed of in general waste or landfill.

Please contact your local dealer, national distributor or Raymarine Technical Services for information on product disposal.





# Chapter 1: Before you begin

The ST70 Autopilot controller is the interface to your autopilot system. It must be installed correctly following the instructions in this guide. For a safe and successful installation, we recommend a certified installation.

## 1.1 Installation overview

The key steps in the procedure are as follows:

### Planning

1. Plan your system.
2. Decide where to locate the ST70 autopilot controller.
3. Check parts.

### Installing

1. Fit ST70 cable to SeaTalk or SeaTalk<sup>ng</sup> system.
2. Cut required holes.
3. Connect the controller.
4. Test the system.
5. Secure the controller in position.

## 1.2 Certified installation

Raymarine recommends certified installation by a Raymarine approved installer. A certified installation qualifies for enhanced warranty benefits. Contact your Raymarine dealer for further details and refer to the separate warranty card packed with your product.

## 1.3 Further assistance

Comprehensive customer support is available online and by telephone.

### **www.raymarine.com**

In the Customer Service area you will find:

- Frequently Asked Questions (FAQs).
- Servicing information.
- Email access to the Raymarine Technical Support Department.
- Details of Raymarine agents worldwide.

### **Telephone helpline**

#### **In the USA**

+1 603 881 5200 extension 2444

#### **In the UK, Europe, the Middle East or the Far East**

+44 (0) 23 9271 4713 (voice)

+44 (0) 23 9266 1228 (fax)

## Help us to help you

When requesting service, please quote as much of the following product information as possible:

- Product type
- Model number
- Serial number
- Software issue number

## 1.4 Product documents

The following documents are available from [www.raymarine.com/handbooks](http://www.raymarine.com/handbooks) to help you install and operate the ST70 autopilot controller:

Document	Part number
<b>ST70 Autopilot Controller Installation Guide (this document).</b>	<b>87071-1</b>
<b>SPX System Commissioning Instructions (supplied with the ST70 autopilot controller).</b> Following installation of the ST70 controller, you must use these instructions to commission your autopilot system before it can be used safely.	<b>81287-1</b>
<b>SPX System Installation Guide.</b> Instructions for installing an autopilot system based around the SPX SmartPilot computer.	<b>87072-1</b>
<b>SeaTalk<sup>ng</sup> Reference Manual.</b> This provides detailed information regarding SeaTalk <sup>ng</sup> connectivity.	<b>81300-1</b>
<b>Autopilot Operating Guide (supplied with the ST70 autopilot controller).</b>	<b>81289-1</b>
<b>Product installation guides.</b> Separate installation sheets are provided with individual components of the autopilot system including the compass, rudder reference sensor and drive	

To the best of our knowledge, the information in the product documents was correct when they went to press. However, Raymarine cannot accept liability for any inaccuracies or omissions in product documents.

In addition, our policy of continuous product improvement may change specifications without notice. Therefore, Raymarine cannot accept liability for any differences between the product and the accompanying documents.

# Chapter 2: Planning

## 2.1 System overviews

The ST70 autopilot controller is connected to the boat's data system, which could be SeaTalk<sup>ng</sup> or SeaTalk.

### SeaTalk<sup>ng</sup>

The diagram below shows how the ST70 controller fits into a typical SeaTalk<sup>ng</sup> system.

#### Typical Seataalk<sup>ng</sup> system with autopilot

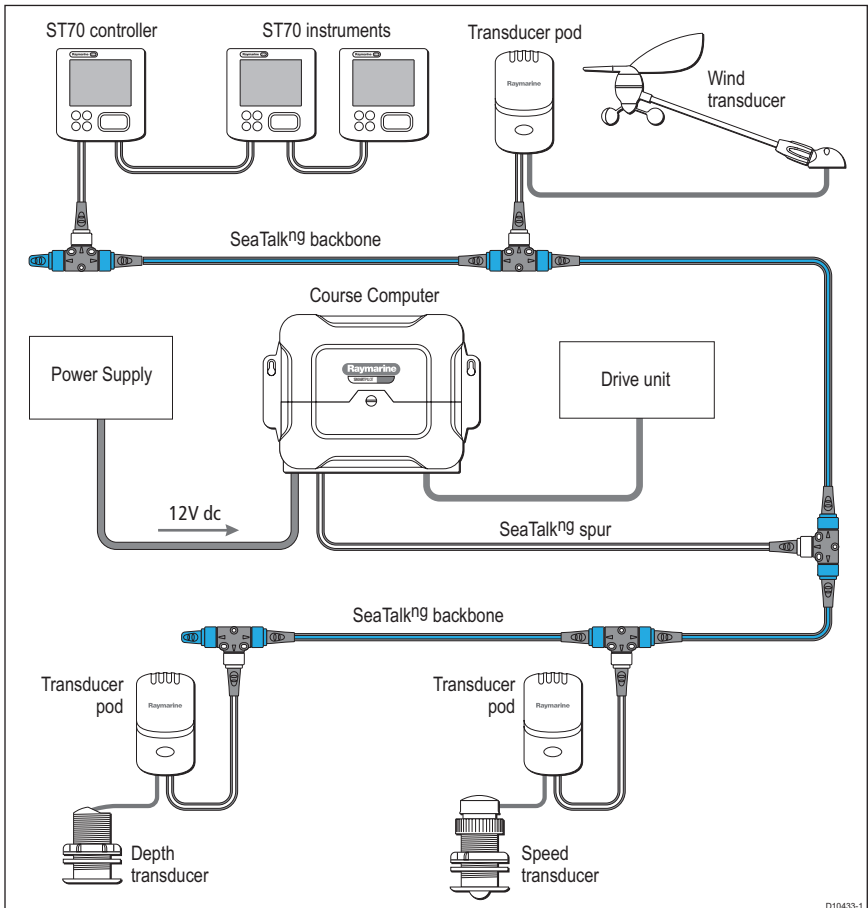

## SeaTalk<sup>ng</sup> system structures and load limitations

There are restrictions on cable lengths, power location and the number of components you may connect to a SeaTalk<sup>ng</sup> system. For complete information on SeaTalk<sup>ng</sup> connectivity, refer to the **SeaTalk<sup>ng</sup> Reference Manual** supplied with the SeaTalk<sup>ng</sup> Backbone Kit. See *page 8* for information about additional SeaTalk<sup>ng</sup> cables and accessories, including the SeaTalk<sup>ng</sup> backbone kit.

### SeaTalk

In a typical SeaTalk system, the ST70 autopilot controller is connected to an existing instrument on the SeaTalk system using a SeaTalk<sup>ng</sup>-to-SeaTalk adaptor cable.

### Typical SeaTalk system with autopilot

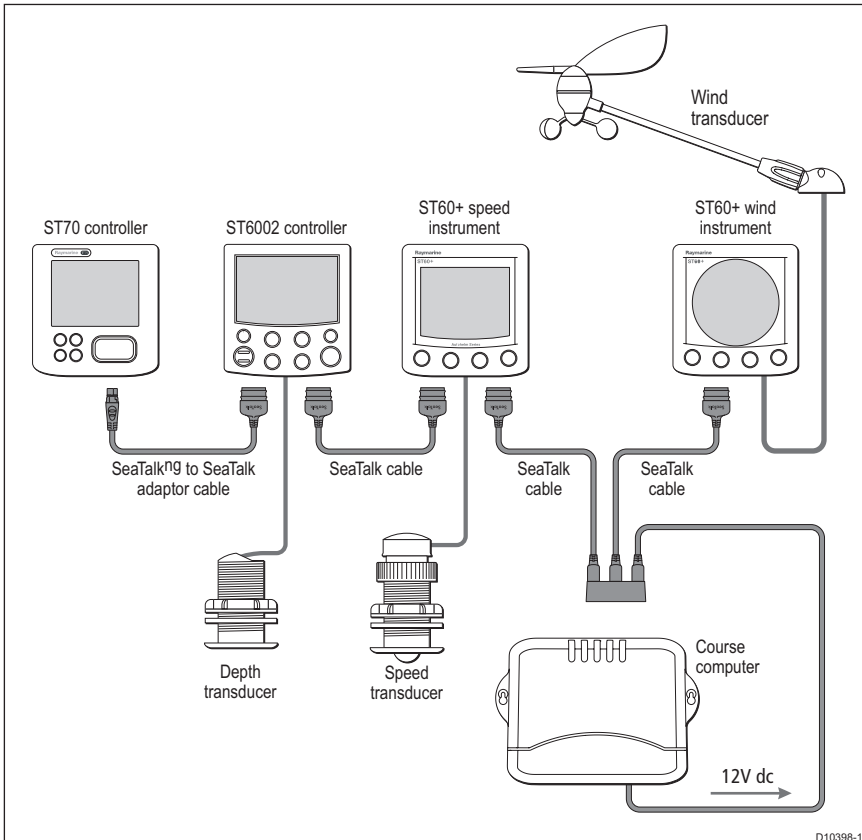

**Note:** You cannot calibrate an S1, S2 or S3 SmartPilot computer with an ST70 autopilot controller, you must use a SmartPilot controller.

## 2.2 Positioning the ST70 autopilot controller

**CAUTION: The autopilot controller must be placed a safe distance from equipment that could adversely effect its performance. Refer to the EMC guidelines on.**

- There must be sufficient space to mount the autopilot controller.
- There should be no obstacles between the user and the autopilot controller.
- The connection point should be within 400mm of the install location (unless you are using an extension cable). In a SeaTalk<sup>ng</sup> network, the connection point will be a T-piece or connector block on the backbone cable, or another ST70 instrument; on SeaTalk, the connection point will be an existing instrument, or a connector block on the system.
- Any holes cut to mount the instrument must not compromise the vessel's structure.

### Site requirements

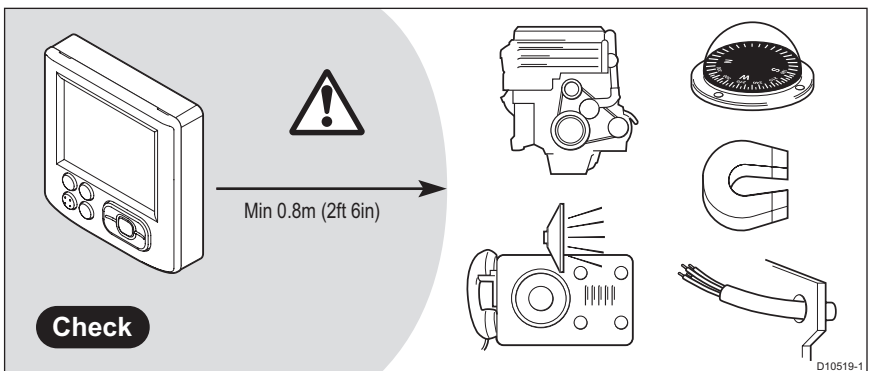
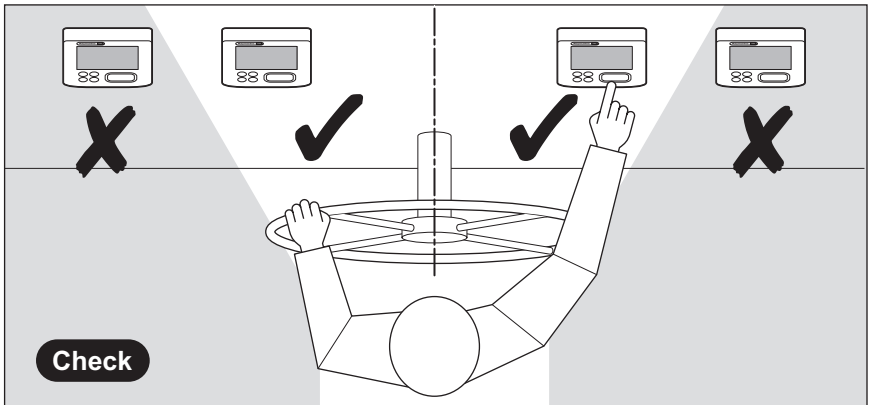

The diagram below shows dimension measurements for the ST70 controller.

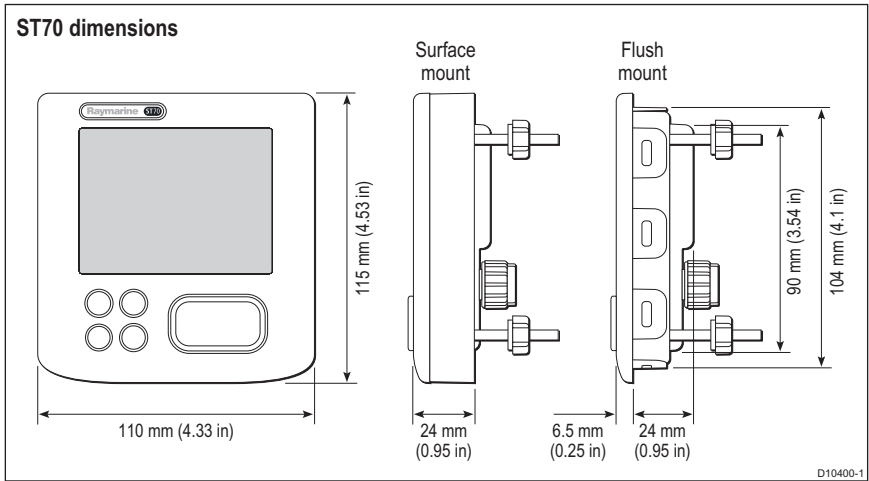

### 2.3 Parts supplied

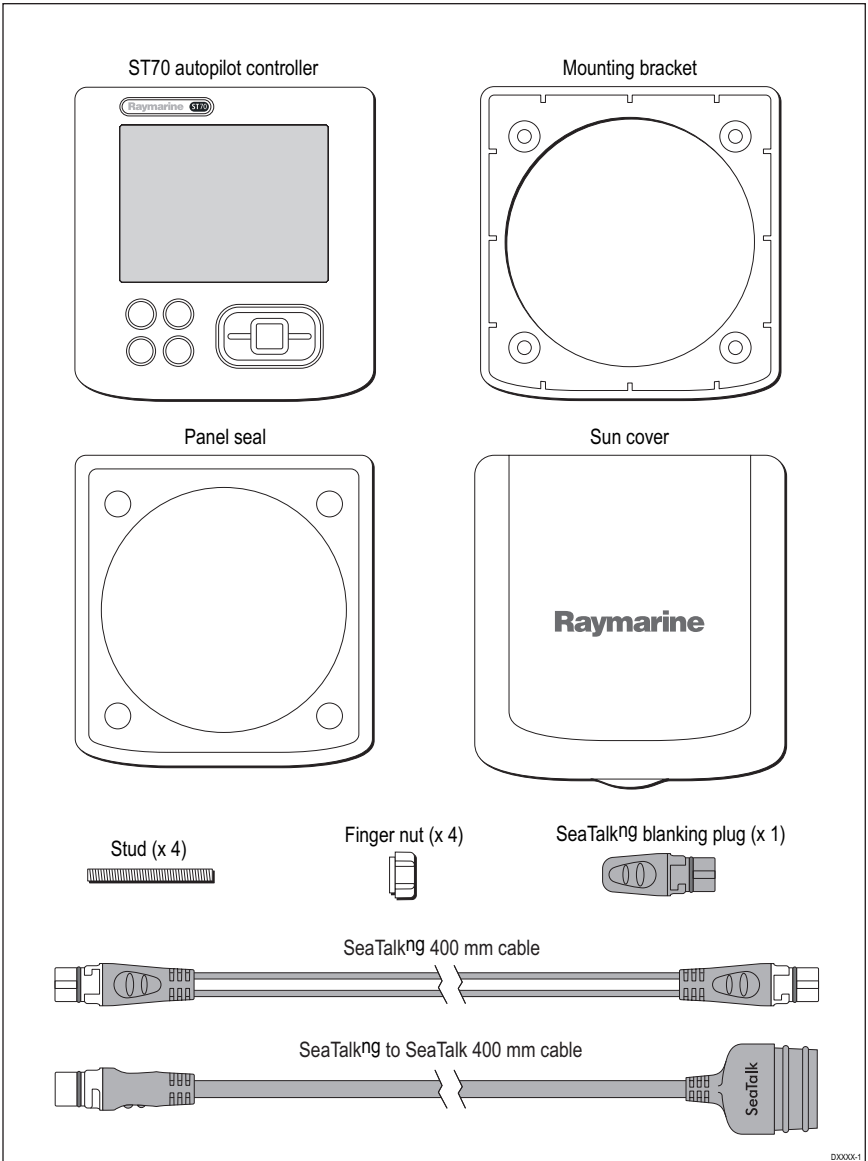





## 2.4 Parts not supplied

The ST70 autopilot controller is connected to a SeaTalk or SeaTalk<sup>ng</sup> data system. To install the controller to your system correctly, you may require additional cables and connectors.

### Optional cabling and connectors

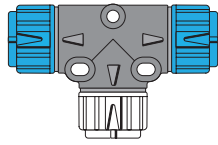
Depending on the location of your ST70 autopilot controller, you may require a longer cable to connect it to the SeaTalk<sup>ng</sup> backbone cable. The backbone cable is supplied as part of a standard kit. Detailed information on SeaTalk<sup>ng</sup> connectivity is available in the SeaTalk<sup>ng</sup> Reference Manual supplied with the SeaTalk<sup>ng</sup> backbone kit. For further information, talk to your dealer or visit the Raymarine website: [www.raymarine.com](http://www.raymarine.com).

<b>Spur cable</b>	<b>Part number</b>
	A06038 - 1 ft 3 in (400 mm)
	A06039 - 3 ft 3 in (1 m)
	A06040 - 9 ft 10 in (3 m)
	A06041 - 16 ft 4 in (5 m)
<b>Backbone kit</b>	<b>A25062</b>
	Backbone cable - 16 ft 4 in (5 m), (x 2) 65 ft 7 in (20 m)
	T piece, (x 4)
	Backbone terminator, (x 2)
	Power cable



# Chapter 3: Installation

Read Chapter 1 of this book before you continue. This will help you to:

- Identify the correct installation location and appropriate network connection point.
- Obtain the appropriate tools and connecting cables.



## WARNING: Electrical safety

**Before you make any electrical connections, ensure the power supply is switched off and you have read the EMC installation guidelines (see *page 4*).**

**CAUTION: For safety reasons your boat must be at dockside before commencing installation.**

## 3.1 To install the autopilot controller

Once you are certain it is safe to proceed, carry out the installation tasks listed below in order.

### 1. Fit cable to system connection point and route to ST70 controller location

#### SeaTalk<sup>ng</sup> systems:

- Label both ends of the SeaTalk<sup>ng</sup> cable, and attach it to the backbone or an existing ST70 instrument on your system.
- Route the cable to the location where you plan to mount the ST70 controller.

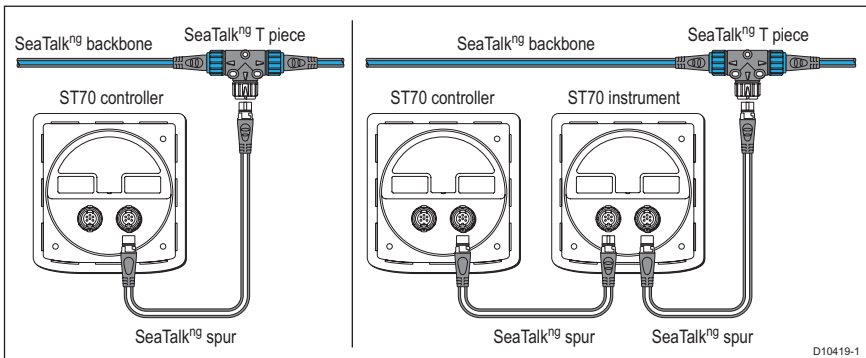

### SeaTalk systems:

- Label both ends of the SeaTalk<sup>ng</sup>-to-SeaTalk adaptor cable, and attach it to an existing instrument or connect it to a connector block on the system.
- Route the cable to the location in which you plan to mount the ST70 controller.

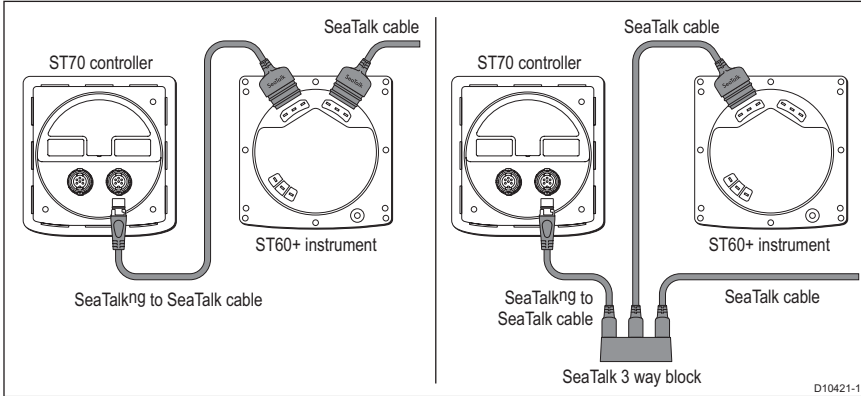

**Note:** Check that the cable reaches the required location. If you wish to place the ST70 controller further than 400mm from the connection point you will need to purchase an appropriate SeaTalk<sup>ng</sup> or SeaTalk<sup>ng</sup>-to-SeaTalk cable.

### 2. Cut mounting holes

- Use the appropriate flush- or surface-mount template to cut the mounting slot for the autopilot controller and to drill holes for the fixing screws. See the back of this book for templates.
- Clean and de-burr the mounting surface

### 3. Fit gaskets and brackets

**Note:** Stick the self-adhesive side of the gasket to the instrument, NOT to the mounting location.

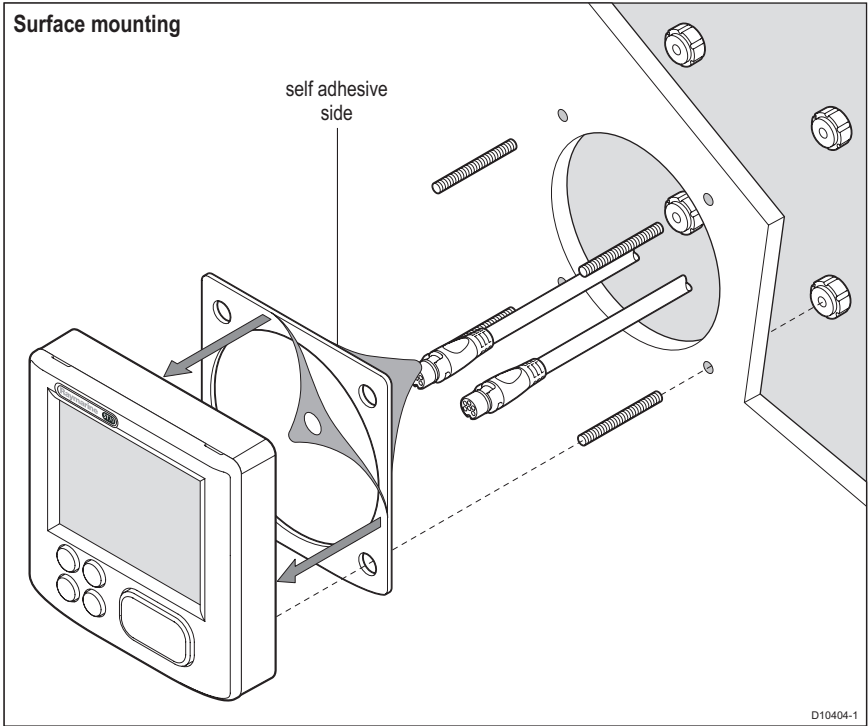

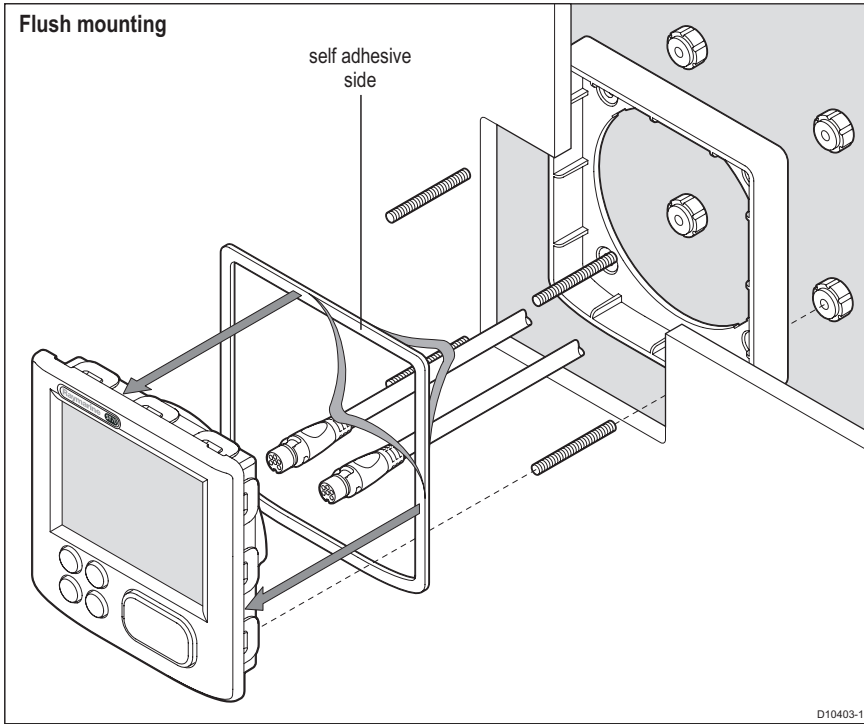
**Flush mounting**

#### 4. Attach connection cable to the controller

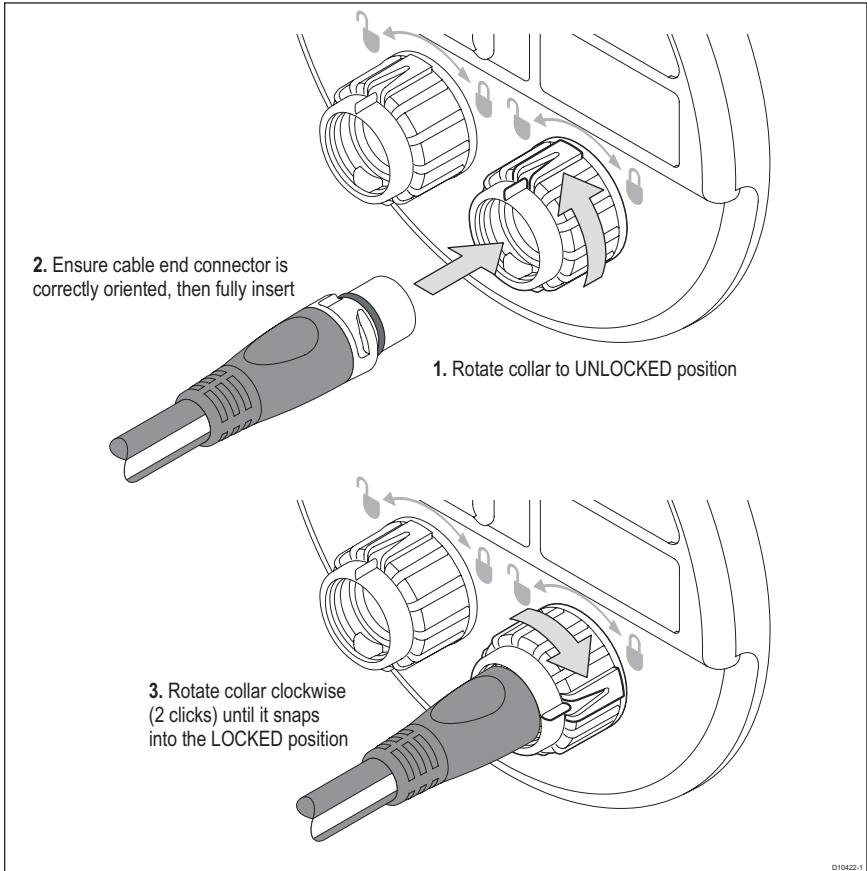

#### 5. Final fix

- Ensure the controller is mounted securely.

## 3.2 Commissioning

The autopilot must be commissioned prior to use. For new systems this involves calibrating the system, which is a **safety-critical** action.

Refer to the SPX SmartPilot System Commissioning Guide for instructions.



## Chapter 4: Technical specifications

---

<b>Supply voltage:</b>	Nominal 12 V dc Maximum 16 V dc Minimum 10 V dc Absolute maximum: 18.5 V dc
<b>Current:</b>	Nominal – dependent on screen brightness setting Maximum – not more than 220 mA
<b>Dimensions (excluding studs)</b>	4.33 in W x 4.53 in H x 1.28 in D (110 mm x 115 mm x 32.5 mm)
<b>Connections</b>	Two SeaTalk <sup>ng</sup>
<b>Operating temperature</b>	-20° to +70°C
<b>Illumination</b>	Sliding scale
<b>Compliances</b>	RoHS EMC EN60945 Revision 4
<b>Buzzer</b>	Monotone buzzer (3.9 kHz)
<b>Load Equivalency Number (LEN)</b>	5

---

**Note:** The LEN (Load Equivalency Number) contributes to the overall system load. Your system has a maximum load capacity, which must not be exceeded. For more detailed information on SeaTalk<sup>ng</sup> system capacity refer to the SeaTalk<sup>ng</sup> Reference Manual.





# Chapter 5: Templates

